

RoHS

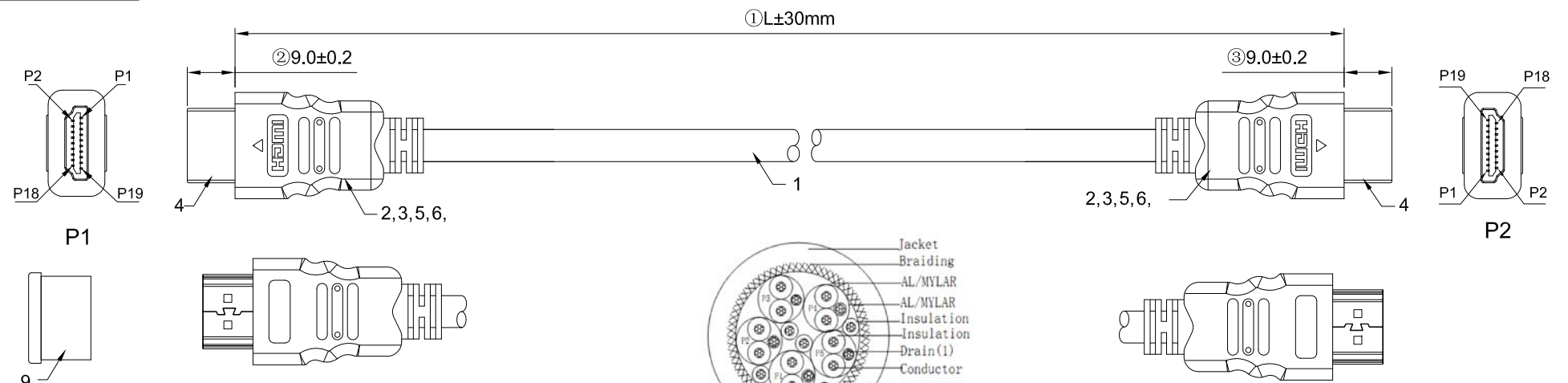

HDMI 19P/F MOLDING TYPE
 INNER MOLD NO.:HJ-CT-233-3/4-091-234-112
 OUTER MOLD NO.:HJ-CT-092/093

HDMI 19P/F MOLDING TYPE
 INNER MOLD NO.:HJ-CT-233-3/4-091-234-112
 OUTER MOLD NO.:HJ-CT-092/093

SA201111030

Pin Assignment

Part Number:

LHDM-19F19F301-XXXX

Part Number	Length
LHDM-19F19F301-1000	1000mm
LHDM-19F19F301-1500	1500mm
LHDM-19F19F301-2000	2000mm

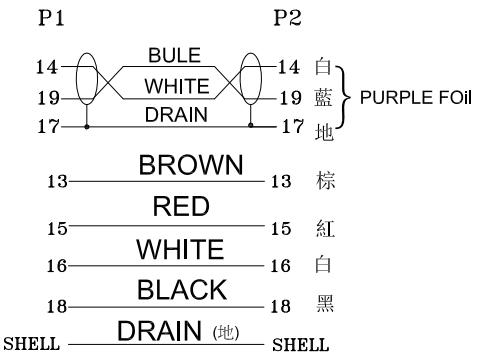
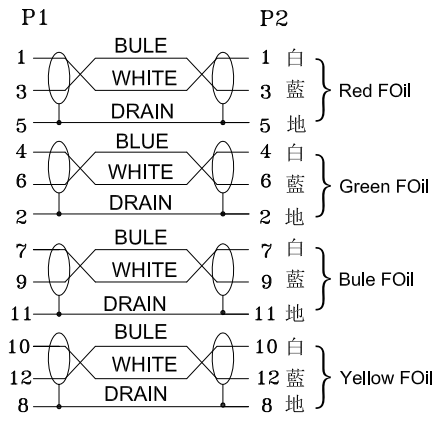

A	03/18/11	RELEASED FOR PRODUCTION	
REV	DATE	DESCRIPTION	
UNLESS OTHERWISE SPECIFIED, DIMENSIONS ARE IN MM. TOLERANCES ARE:		CAD GENERATED DRAWING, DO NOT MANUALLY UPDATE	
DECIMALS	ANGLES	APPROVALS	DATE
.X ± .38	± 3°	DRAWN Chris	03/18/11
.XX ± .25		CHECKED Cindy	03/18/11
.XXX ± .20		APPV Jason	03/18/11
DO NOT SCALE DRAWING	SHEET 1 OF 1	SCALE NONE	DWG NO. LHDM-19F19F301-XXXX



Cable Assembly (Type A to Type A)
 HDMI A/F - HDMI A/F (2.80Meter 30AWG)

LHDM-19F19F301-XXXX

REV. A

RoHS

NOTE:

1.HDMI CABLE:[(30AWG*1P+D+FAM)*5P+30AWG*4C]
 +AEB PVC JACKET,COLOR/BLACK(BK-01) OD:6.0±0.2mm
 PRINT WORD: "E189529 AWM 20276 80°C 30V
 HDMI cable"

2.CONNECTORS
 HDMI 19P/FEMALE TO HDMI 19P/FEMALE

3.ELECTRICAL TEST
 (1).100% open short & miss wire test;
 (2).Insulation resistance:DC/300V ≥5Mohm;
 (3).Contactor resistance:≤3ohm Max;

4.HDTV-DVD TEST:1080P

5.RoHS compliant

6.PACKING:1PC/PE BAG

PACKING DRAW

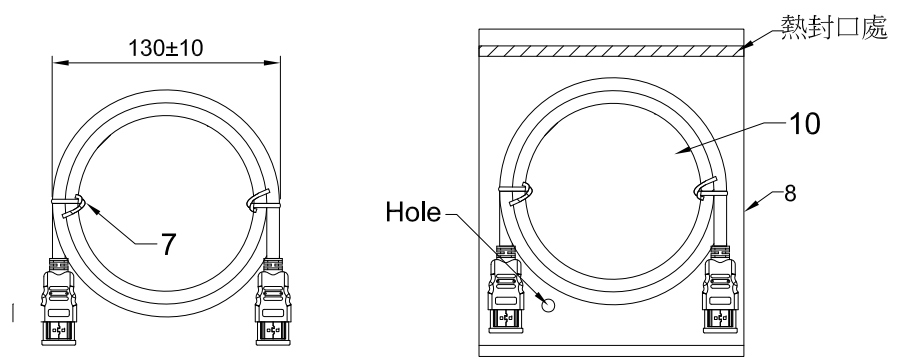

Part Number:
 LHDM-19F19F301-XXXX

Part Number	Length
LHDM-19F19F301-1000	1000mm
LHDM-19F19F301-1500	1500mm
LHDM-19F19F301-2000	2000mm

Item	Name	Specifications	QTY	UNIT
10	Label	Colorful Label (EMHD 1206 W=110*H=120MM)	1	PC
9	HDMI Cover	LDPE 3g	3	g
8	PE Bag	W165(Opening Side)*L205*T0.08mm (Hole in the bottom of Left)	1	PC
7	Tie	L=100mm Black	2	PCS
6	Molding	PVC-45P BK-01	15	g
5	Molding	LDPE	8	g
4	HDMI(M)	HDMI 19P(F)Shielding Gold 1u", Pin Gold 30u", Black Color	2	SET
3	Clip	30AWG 1.4V Clip (Ground with insulation)	2	PCS
2	H.S.T.	Φ0.6*L20mm (Black)		
1	Cable	{{[1/0.254CCS+FPE ID0.75*1P+D1/0.254CCS+FAM]*5C+(1/0.254CCS+HDPE ID0.65*4C)}}+AL+D1/0.254CCS+B64/0.12ALMG+PVC OD6.0mm	1	PC

A	03/18/11	RELEASED FOR PRODUCTION	
REV	DATE	DESCRIPTION	
UNLESS OTHERWISE SPECIFIED, DIMENSIONS ARE IN MM TOLERANCES ARE:		CAD GENERATED DRAWING, DO NOT MANUALLY UPDATE	
DECIMALS	ANGLES	APPROVALS	DATE
.X ± .38	± 3°	DRAWN Chris	03/18/11
.XX ± .25		CHECKED Cindy	03/18/11
.XXX ± .20		APPV Jason	03/18/11
DO NOT SCALE DRAWING		SHEET 1 OF 1	SCALE NONE
		DWG NO. LHDM-19F19F301-XXXX	REV. A



凱聯科技股份有限公司
Conn-Link Technology Inc.

DESCRIPTION Cable Assembly (Type A to Type A)
 HDMI A/F - HDMI A/F (2.80Meter 30AWG)

RoHS

Pack a case Draw :

ONE PC WITH ONE PE BAG+LABEL.

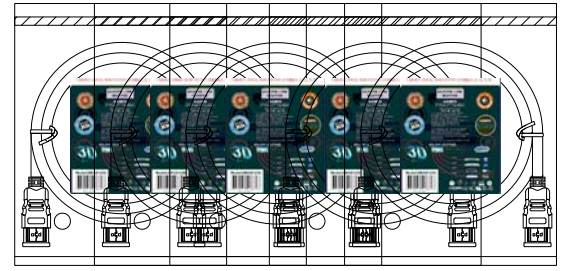
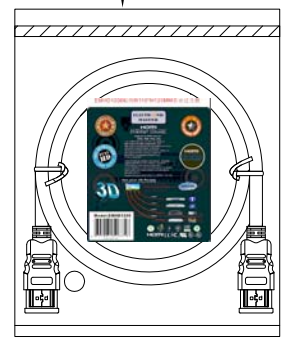

(PACKING Q'TY:100PCS/CARTON)

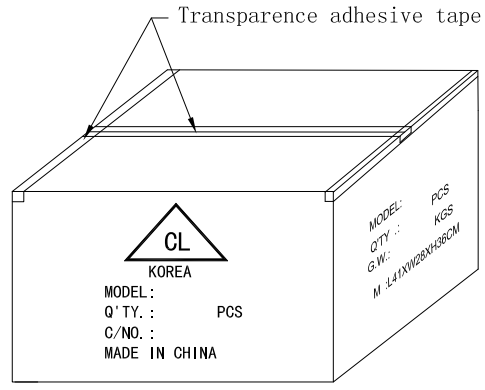
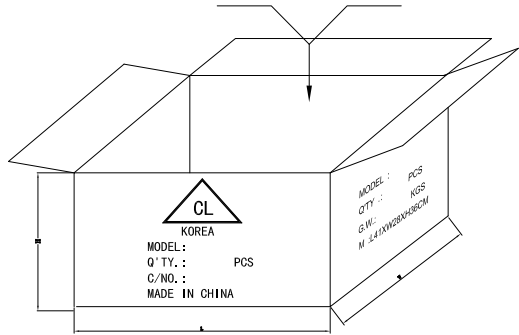

SHIPPING MARK:

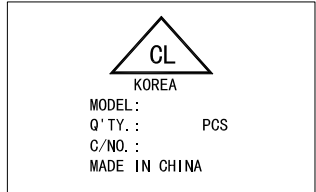

SIDE MARK:

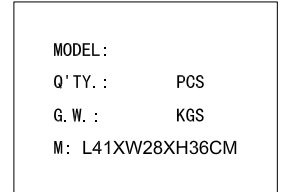

NOTES:

- 1>.PACKING:1PC/PE BAG+LABEL
- 1>.包装:每条线要装1PC PE袋+贴纸
- 2>.100PCS/OUTER CARTON
- 2>.每100PCS装一个外箱
- 3>.OUT CARTON SIZE: K=K L41XW28XH36CM
- 3>.外箱尺寸: K=K L41XW28XH36CM
- 4>.隔板尺寸: B3B L40XW27CM

A	03/18/11	RELEASED FOR PRODUCTION		
REV	DATE	DESCRIPTION		
UNLESS OTHERWISE SPECIFIED DIMENSIONS ARE IN MM TOLERANCES ARE:		 凱聯科技股份有限公司 Conn-Link Technology Inc.		
DECIMALS	ANGLES			
.X ± .38	± 3°			
.XX ± .25				
.XXX ± .20		APPROVALS	DATE	
		DRAWN	Chris	03/18/11
		CHECKED	Cindy	03/18/11
		APPV	Jason	03/18/11
DO NOT SCALE DRAWING		SHEET	SCALE	DWG NO.
		1 OF 1	NONE	LHDM-19F19F301-XXXX